

I telai scrivania regolabili in altezza sono specificamente progettati per l'utilizzo in scrivanie ergonomiche e tavoli di lavoro. Vi fornisce pieno movability: Creare la progettazione di mobili in stile classico, elegante o high-tech! Tutti i nostri prodotti di essere di prova per oltre 20.000 volte per assicurarsi che in fase di costruzione in modo sicuro e durevole.

I nostri prodotti offrono ai clienti le soluzioni di cui hanno bisogno per soddisfare le loro esigenze di progetto ambiente di lavoro. Il telaio è disponibile in 3 colori classici: nero, Pentecoste e Grey.



Color available:black,greyscale,white

### A6 Series Dual-motor Three sections

2 legs / 2 motors  
Super mute motor synchronization control system  
Colours can choose Black,White and silver gray  
Limit Switch inside  
Touch screen memory handset

Lifting range from 620mm-1270mm  
Frame adjust from 1100mm-1600mm  
Load capacity: 120kg / 265IBS  
Full load Speed: 30mm/s

Input Voltage : AC 90V~230V can use  
Output Voltage : DC 24V  
Duty Cycle : Max.10%  
Run into obstacles will stop

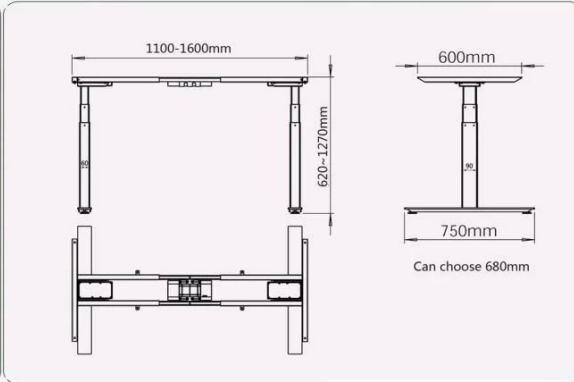

Other part:  
Packing Size : 1080\*270\*325mm  
Gross Weight : 40KG

